

# Sierra Stained Glass Studios

## The Dome & SupraDomes

PATENTED, U.S. PATENT OFFICE, Patent No. 5,130,915

1153 Yale Ave Modesto CA 95350-5850 209-448-0350 FAX: 209-529-0632 e-mail: sierradomes@pacbell.net  
Visit us on the World Wide Web: <http://www.sierradomes.com>

**The Dome™** is our 4' octagonal frame; **SupraDomes™** are larger frames, 6' - 10' (12-, 16-, or 24-sided); **The Dome....Inverted!™** is our 4' convex octagonal frame.

Thank you for your interest in **The Dome**. Enclosed is our color brochure that describes our standard 45.5" dome. (Available from [www.isgs.com](http://www.isgs.com) Section D) The frame comes with four full-sized patterns as shown on pg. 4 of the brochure along with installation instructions. You make **separate flat panels** (25) that merely set & interlock into the frame. No soldering over molds or curves! Order #4850 (Black) or #4860 (White). Each frame comes with detailed installation instructions for the ~12-16 hour process for retrofits. (New construction requires only one hour of additional labor.)

We offer extension kits for the 4' frame which also are available from your stained glass dealer. Our larger dome frames, **The SupraDomes**, also are shown on the reverse side. These frames use the same patented process of holding simple flat glass projects that merely set into the frame as our 4' version--the projects are merely a bit larger and greater in number. **SupraDomes** are available in these sizes: 69.25" & 77.5" (12-sided versions for 30 & 39 sq.ft. of glass), 93.5" (12- or 16-sided, 56 sq.ft.), and 123" (24-sided, 96 sq.ft.). Total weights, frame with glass, are 124, 153, 220, and 380 lbs. respectively. You can purchase the SupraDomes directly from us.

Here's a photo of our newest product, **The Dome....Inverted!**, which requires no special installation work since it merely bolts to the ceiling. It looks best in rooms with at least 9' ceilings. Like **The Dome**, it comes with four full-sized patterns (De'nouement, Cascade, Victorian, and Nouveau) and requires a total of 25 separate glass panels which easily lift out for cleaning. And, the wood trim is included! The standard frame color is verdigris, a dark bluish-green textured finish. This is a lighting fixture that gives you a chance to show your craftwork off in real style. And, because the glass panels are easily removed from below (as in all our frames), you can make more than one set of panels and change them with the seasons! One of our customers even made a special set just for her Christmas dinner!

Again, thanks for your interest, and best wishes with this new & elegant product.

For more information, visit our website on the internet at:

<http://www.sierradomes.com>





*Clockwise from Upper Left:*  
 1) SupraDome 7 (77.5" / 12-sides) with Customized Textured Clears & Brass Comes & Chandelier center top plate;  
 2) SupraDome 7 (77.5" / 12-sides) with Cascade design;  
 3) The Dome (45.5" / 8-sides) with Bordered Clears & Brass Comes & Chandelier center top plate, white frame;  
 4) The Dome Elongated (4' x 5') with Nouveau design;  
 5) & 6) SupraDome 10 (123" / 24-sides) with custom design.





SupraDome 6'  
(12-sided)

Both dome frames  
from the patented  
line of dome frames  
manufactured by  
Sierra Stained  
Glass Studios  
Modesto, CA



SupraDome 8'  
(16-sided)

AdiVictorian Design in Plum & Amber Colors



*The Domes of  
Martin Lawrence Galleries  
366 Geary Avenue  
of San Francisco, CA*

# Standard Recessed Dome Frames

Effective 3/1/22

All frames are shipped disassembled by UPS or FedEx Ground.

Assembly time required: ~0.3 to 1 hr.

## Key Data on Frames & Installation Framing

( See Typical Installation Guidelines for more detailed information. 12-, 16-, and 24-sided frames normally installed over ROUND openings.)

| Frame Number | Frame Size (at base) / No. of Sides | Frame Height inches | Weight Frame (lbs) | Weight, Frame + Glass | *No. of Glass Panels | Installation Framing, Centers | **Soffit Height | Frame Only Price |
|--------------|-------------------------------------|---------------------|--------------------|-----------------------|----------------------|-------------------------------|-----------------|------------------|
| 4850         | 45.5" / 8-sided                     | 12                  | 18                 | 57                    | 24/25                | 48x48                         | 15"             | \$580            |
| 4850X5       | 45.5" x 57.5" / 8                   | 12                  | 20                 | 71                    | 25                   | 48x60                         | 15"             | 795              |
| 4850X6       | 45.5" x 69.5" / 8                   | 14                  | 24                 | 88                    | 32                   | 48x72                         | 16"             | 980              |
| 4850X8       | 45.5" x 93.5" / 8                   | 14                  | 30                 | 118                   | 39                   | 48x96                         | 16"             | 1360             |
| 4850X10 ***  | 45.5" x 117.5" / 8                  | 14                  | 37                 | 149                   | 46                   | 48x120                        | 16"             | 1735             |
| 5250 ***     | 57.8" x 57.8" / 12                  | 14                  | 28                 | 90                    | 36/37                | 60x60                         | 18"             | 910              |
| 5250X8 ***   | 57.8" x 93.5" / 12                  | 16                  | 40                 | 148                   | 51                   | 60x96                         | 19"             | 1660             |
| 5850 ***     | 57.6" x 57.6" / 8                   | 16                  | 23                 | 89                    | 24/25                | 60x60                         | 19"             | 950              |
| 5853X7 ***   | 57.6" x 81.5" / 8                   | 18                  | 33                 | 130                   | 39                   | 60x84                         | 21"             | 1485             |
| 6250         | 69.3" / 12-sided                    | 18                  | 34                 | 124                   | 36/37                | 72x72                         | 22"             | 1275             |
| 6250X10 ***  | 69.3"x123.3" / 12                   | 20                  | 54                 | 229                   | 58                   | 72x126                        | 23"             | 2580             |
| 6250X12 ***  | 69.3"x141.5" / 12                   | 20                  | 61                 | 265                   | 65                   | 72X144                        | 23"             | 3000             |
| 6800 ***     | 69.6" x 69.6" / 8                   | 18                  | 27                 | 123                   | 24/25                | 72x72                         | 22"             | 1350             |
| 7250         | 77.5" / 12-sided                    | 20                  | 38                 | 153                   | 36/37                | 80x80                         | 24"             | 1615             |
| 7250X10 ***  | 77.5"x117.5" / 12                   | 22                  | 54                 | 240                   | 51                   | 80x120                        | 25"             | 2735             |
| 7250X13 ***  | 77.5" x 160" / 12                   | 22                  | 69                 | 330                   | 65                   | 80x162                        | 25"             | 3850             |
| 8250 ***     | 93.5" / 12-sided                    | 23                  | 46                 | 213                   | 36/37                | 96x96                         | 28"             | 2365             |
| 8250X10 ***  | 93.5"x117.5" / 12                   | 25                  | 55                 | 275                   | 44                   | 96x120                        | 29"             | 3235             |
| 8650         | 92.6" / 16-sided                    | 23                  | 54                 | 215                   | 48/49                | 96x96                         | 28"             | 2275             |
| 8650X12 ***  | 92.6"x146.5" / 16                   | 25                  | 79                 | 355                   | 70                   | 96x149                        | 29"             | 4060             |
| 8856 ***     | 93.5"/8-sided 16§                   | 24                  | 43                 | 220                   | 48/49                | 96x96                         | 29"             | 2615             |
| 9653 ***     | 106"/16-sided                       | 25.5                | 62                 | 277                   | 48/49                | 108x108                       | 30"             | 2850             |
| 10450        | 123" / 24-sided                     | 29                  | 97                 | 380                   | 73                   | 10' circle                    | 37"             | 3775             |
| 12450****.75 | 147" / 24-sided                     | 37                  | 148                | 570                   | 73                   | 12' circle                    | 48"             | 5475             |

\* Frames with hanging chandelier (xxxx-5) center have no center glass panel.

\*\* Soffit (above dome for lighting) must be sealed tightly to prevent glass panels from lifting out!

\*\*\* These frames are non-standard and not always in stock. Allow time for custom manufacture.

\*\*\*\* Frames larger than 10' are not fully self-supporting frames. (Requires cable supports for each arm.)

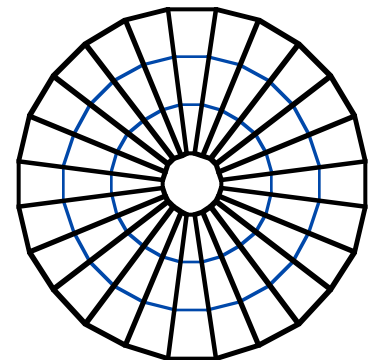

10450, 11450, 12400

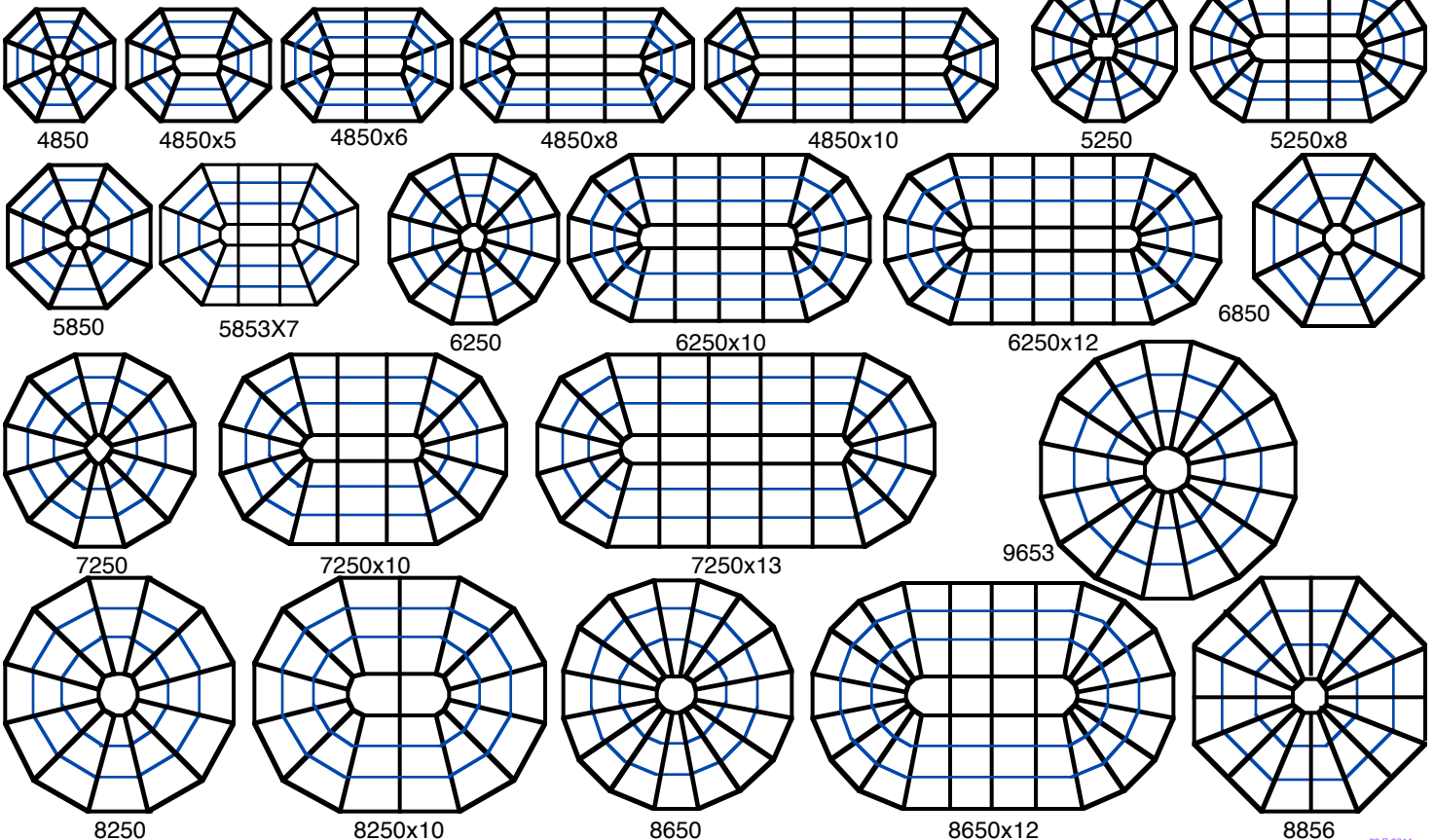

# Sketch of Typical Framing & Sheetrock Sizing for 12-sided frame.

4/1/02

v2.3

ALL DIMENSIONS IN INCHES (NOT TO SCALE)

© Sierra Stained Glass Studios 1992-2002

SupraDome 6200 6' (69.2" x 69.2" 12-sided)

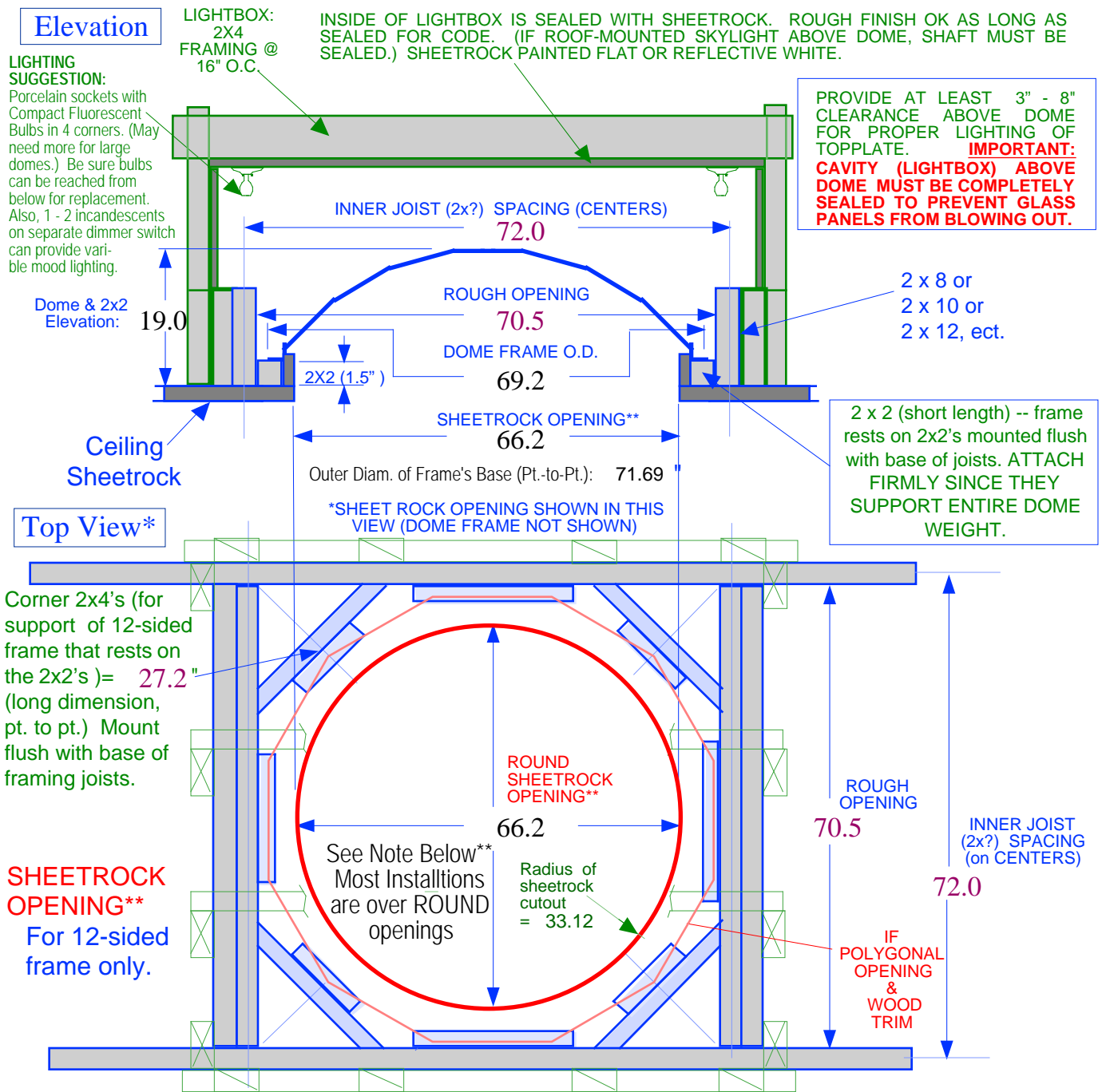

\*\*Most 12-sided frames are installed over a CIRCULAR opening. Make diameter of opening 3" less than frame O.D. across paralld sides. Note: When circular opening planned, frame must be installed before sheetrocking circular opening. The vertical sheetrock trim is wet, then bent to shape.

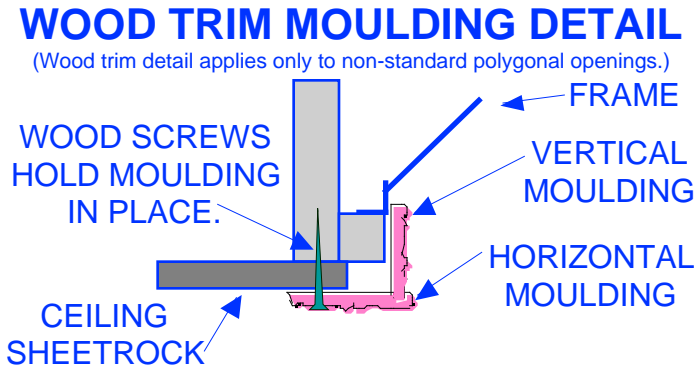

*For 12-sided 69.2" frame Only!*

DISCLAIMER: Selection of Sierra Stained Glass products to conform to all local applicable laws, ordinances, building codes, and safety requirements is the sole responsibility of the architect, house/building owner and/or contractor. Proper installation of our products is the responsibility of the customer. Sierra Stained Glass Studios has no responsibility in these regards. The information on this page is not to be construed as structural requirements for proper & safe installation.

# ! CAUTION !

**THE SHEET-ROCKED SOFFIT (LIGHTBOX) ABOVE DOME MUST BE PROPERLY SEALED AND NOT VENTED TO ATTIC NOR EXTERIOR FOR MEETING BUILDING CODES & SAFETY REQUIREMENTS.**

**Failure to observe this caution can result in glass panels lifting out of the frame and falling!**

For example, on a windy day when a window or door is opened to the wind, the air pressure can blow or suck out the glass panels if the area above the dome has any exposure to the building's exterior. (Remember, the glass panels are held in place by gravity so they can be easily removed from below for cleaning or changing light bulbs.) Also, leaded glass does not qualify as a fire break to prevent the spread of fire to the attic or other areas above the dome.

If the area above the dome is accessible from the attic or another room, caution must be taken to seal and lock the access door/panel to prevent such sudden air pressure differences from lifting or sucking out the glass panels. Do not attempt to open such access door/panel on a windy or gusty day. Always open access door/panel slowly to allow any pressure differences to equalize gradually. Prevent access to such space by children by putting a padlock on access door. ALSO, A COPY OF THIS CAUTION SHOULD BE POSTED ON OUTSIDE OF ANY SUCH ACCESS DOORS.

If skylight is installed above dome, the skylight must be a fixed type (can't open) and it must be shafted with sheet-rock to form a sealed space holding dome.

THE LIGHTBOX ABOVE DOME SHOULD BE PAINTED WITH FLAT WHITE PAINT, OR A HIGH REFLECTIVE WHITE PAINT, FOR BEST REFLECTIVITY OF LIGHT. If painted with a color the colors of the dome's glass panels will be distorted by the reflected light.

Do not seal the space between the dome frame and the ceiling's trim moulding. This gap is necessary to equalize air pressure above and below the dome, and allows the area above the dome to "breathe" into the room below to avoid condensation buildup in humid or cold climates. Outside of lightbox should be insulated to prevent condensation inside and for general energy conservation.

## ADDITIONAL SAFETY REMINDERS

- When removing glass panels from dome frame, always remove top tier first, then middle tier, then bottom tier last. (This is the reverse of how installed.)
- NEVER LEAN NOR PULL ON DOME FRAME. It is not designed to support the weight of a person. Doing so may cause frame distortion and falling glass.

DISCLAIMER: Selection of Sierra Stained Glass products to conform to all local applicable laws, ordinances, building codes, and safety requirements is the sole responsibility of the architect, house/building owner and/or contractor. Proper installation of our products is the responsibility of the customer, including adherence to above cautions. Sierra Stained Glass Studios has no responsibility in these regards.